

Dräger Alcotest[®] 9510 Standard IR + EC

Breath Alcohol Measuring Instrument

Instructions for Use



Content

For Your Safety	3	Measurement Protocols (Examples)	18
Safety Symbols Used in these Instructions for Use	3	Explanation of the Protocol	19
Intended Use	4	Summer Time/Winter Time Change-Over	19
Transport and Storage	4	Maintenance	20
Function Description	4	Inspection	20
What's What?	5	Maintenance Intervals	20
Front View	5	Inserting Paper Roll	20
Side View	5	Replacing Fuses	20
Back View	5	Cleaning the Instrument	20
Commissioning	6	Disposal of Electric and Electronic Instruments	21
Preparing the Measurement	6	Fault – Cause – Remedy	22
Stationary Use	6	Technical Data	24
Mobile Use	6	Order List	26
Standby Mode	7	Consumables and Accessories	26
Interaction with the Instrument	8	Index	27
Keypad	8		
Screen (Touch Screen)	8		
Screen Standby Mode	8		
Menu	9		
» About « Menu	9		
» Maintenance « Menu	9		
» Settings « Menu	9		
» Printer « Submenu	10		
» Errorlogger « Submenu	10		
» Language « Submenu	10		
» Location Database « Submenu	10		
» Change current location « Submenu	11		
» Service Settings « Submenu	11		
» Set date and time « submenu	11		
» Display « Submenu	11		
Making Measurement	12		
Requirements	12		
Control Time before Measurement	12		
Starting Measurement	12		
Entering Data of Person Being Tested	12		
Delivering a Breath Sample	14		
Finishing the Measuring Cycle	15		
Printing an Additional Measurement Protocol	15		
Faults during the Measurement Cycle	16		

For Your Safety

Strictly follow the Instructions for Use

Any use of the instrument requires full understanding and strict observation of these instructions.

The instrument is only to be used for purposes specified here.

Maintenance

The instrument has to be inspected by experts at least annually.

Repair and general overhaul of the instrument may only be carried out by trained service personnel.

We strongly recommend that a service contract be signed with Dräger Safety to have them handle repairs and maintenance.

Only authentic Dräger spare parts may be used for maintenance.

Be sure to read the information contained in the chapter "Maintenance Intervals", page 20.

Not for use in areas of explosion hazard

The instrument is not approved for use in EX-areas.

Accessories

Only use accessories listed in the order list.

Safe connection of electrical instruments

Do not connect electrical instruments not mentioned in this manual before having contacted Dräger Safety AG & Co. KGaA or an expert.

Safety Symbols Used in these Instructions for Use

While reading these Instructions for Use, you will come across a number of warnings concerning some of the risks and dangers you may face while using the instrument. These warnings have signal words to make you aware of the expected degree of danger. These signal words and the associated dangers are specified as follows:

 CAUTION
Indicates a potentially hazardous situation which, if not avoided, could result in physical injury or damage to the product.
It may also be used to alert against unsafe practices.

NOTICE
Indicates additional information on how to use the instrument.

Intended Use

The Dräger Alcotest® 9510 Standard IR + EC is an Evidential breath alcohol measuring instrument for automatic analysis of the alcohol concentration (ethanol content per respiratory volume) in the exhaled air.

The instrument uses two measuring technologies (EC* and IR**) for analysing the breath alcohol concentration (BrAC).

Transport and Storage

- Usual precautions should be taken for transporting the sensitive, electronically instrument.
- Avoid excessive mechanical strain, shocks, and vibrations when transporting the instrument.
- Store the instrument in dry rooms. For the ambient conditions for storage see "Technical Data", "Storage", page 24.

Function Description

The Alcotest 9510 performs a measuring cycle with a single breath sample to determine the breath alcohol concentration.

During the delivery of the breath sample by forced expiration the exhaled air is led through a mouthpiece into the instrument.

A combination of an infrared optical sensor and an electrochemical sensor with different analytical specificity is used for determining the concentration.

The necessary activities of the operator and the person being tested are indicated by short messages and instructions on the screen (also used as a touch screen) of the instrument.

Only if all individual steps of the breath alcohol determination are performed correctly and if none of the internal test criteria is outside the admitted tolerance, the final result of the breath alcohol measurement is indicated and a protocol is printed on the integrated thermal printer.

The operating steps to be executed on the Alcotest 9510 are supported optically and acoustically. Instructions for the user are given as easily understandable full-text messages on the screen.

® Alcotest is a registered trademark of Dräger

* EC = Electro Chemical

** IR = InfraRed

What's What?

Front View

- 1 Heated breathing hose in storage recess
- 2 Stylus
- 3 Screen (touch screen)
- 4 Start button
- 5 Transport handle
- 6 Unlocking button of the printer flap
- 7 Thermal printer



10228975_01.eps

Side View

- 8 Removable lid
- 9 Mains switch I/O (ON/OFF)
- 10 Main fuse
- 11 Mains inlet
- 12 Dry gas connector (optional)
- 13 Connector 12 V DC
- 14 Monitor connector (optional)
- 15 RS 232 interface, 2x
- 16 USB ports, 3x
- 17 Network connector
- 18 Modem connector (internal modem optional)
- 19 Sealable screw

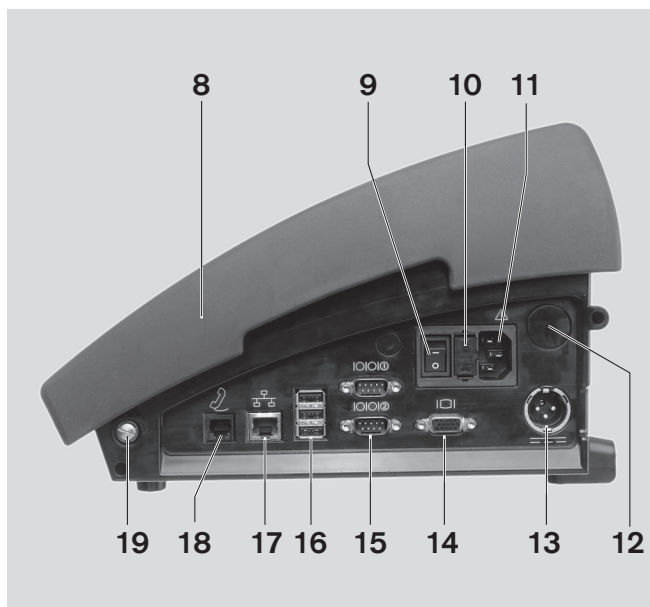

10328975_01.eps

Back View

- 20 Screw of upper part
- 21 Screw of gas inlet (optional)
- 22 Dry gas connector 3 (optional)
- 23 Dry gas connector 2 (optional)
- 24 Gas outlet
- 25 Dry gas connector 1 (optional)
- 26 Service connector of cuvette
- 27 Type plate
- 28 Sealing plate

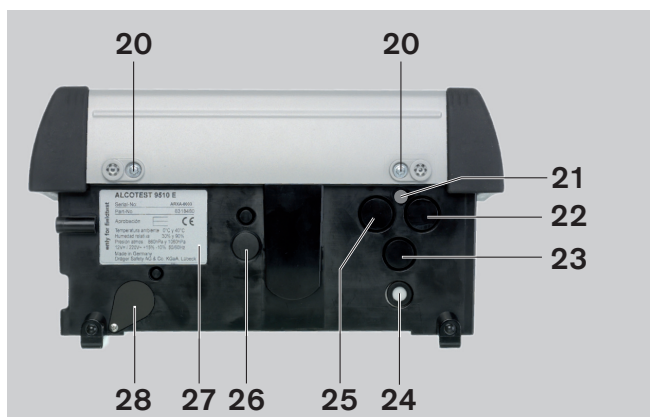

10428975_01.eps

Commissioning

Preparing the Measurement

- Select the installation location such that the gas outlet on the rear side of the instrument is not obstructed and that the instrument is not exposed to direct sun irradiation.
 - Make sure that there is sufficient space for the accessories (keypad, etc.).
 - Place the instrument on an even and solid surface.
- 1 Slightly stretch the instrument lid at the marks and then remove it.
- Check if a paper roll is in the thermal printer. If required insert a new paper roll, see "Inserting Paper Roll", page 20.

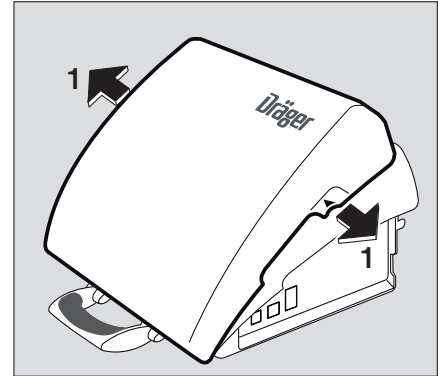

10623875_01 enp

Stationary Use

- Check the mains voltage specification on the type plate.
- 2 Set the mains switch to the left of the mains cable to "0" (OFF).
- Connect the keypad, if keypad operation is planned.
- 3 Connect the mains cable.
 - 2 Set the mains switch to "I" (On).
- The Dräger Alcotest 9510 Standard begins with the warm-up phase.

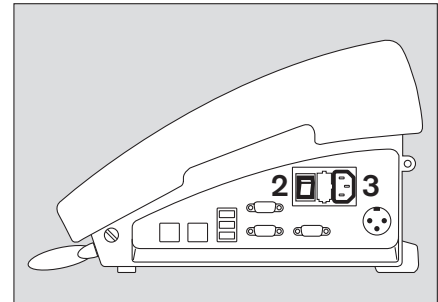

10623875_01 enp

Mobile Use

- A minimum voltage of 10.5 V DC (12 V DC connector) is required for battery operation of the Alcotest 9510 Standard.
- When the input voltage is too low, the instrument is switched off. This prevents deep discharge of the supply battery (e.g. car battery).

Therefore:

- Ensure that the car battery is charged sufficiently or provide an additional battery.

NOTICE
Connector 12 V DC Exclusively connect batteries or electrically isolated DC power units (e.g. acc. to VDE 0551). Risk of damaging of the instrument.

- Connect the keypad, if keypad operation is planned.
- 4 Connect and secure a 12 V connection cable.
- Plug the connector of the connection cable into the 12 V socket of the car or the car cigarette lighter socket (with adapter).
 - Set the switch on the 12 V connection cable to "I" (ON).
- The Dräger Alcotest 9510 Standard begins with the warm-up phase.

NOTICE
Connector 12 V The mains switch of the instrument is not active during 12 V operation.

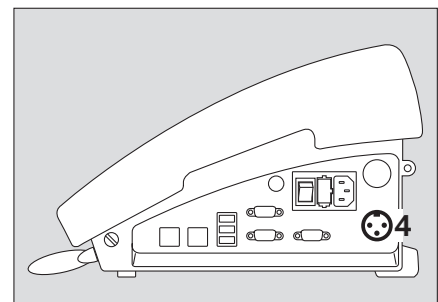

10728075_01 enp

Standby Mode

If no measurement is made for 15 minutes, the instrument is switched to standby mode, and the following display appears:

- The instrument will be ready for measurement again within 3 minutes after pressing the green start button.

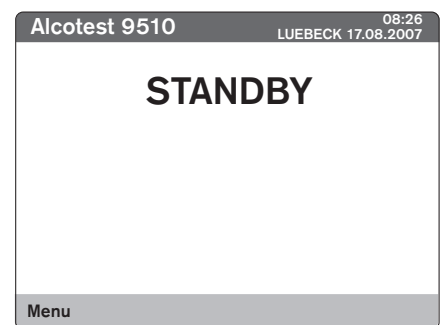

Interaction with the Instrument

Keypad

A USB keypad can be connected to the Alcotest 9510. The keypad is used for:

- entering data of the person being tested for the protocol,
- entering and polling instrument parameters,
- entering fixed texts (like e.g. the agency name or date).

Only a keypad listed as an accessory should be used for entering data, see "Order List", "Consumables and Accessories", page 26.

The use of any other keypad requires the prior permission from Dräger Safety AG & Co. KGaA.

The "Back-Space" key can be used for changing entries.



10923875_01.nppa

Screen (Touch Screen)

Once the instrument has been switched on, it indicates the following information on the screen.

- 1 Instrument type / Instrument name
- 2 Current instrument state
- 3 Information about the location (configurable)
- 4 Date and time
- 5 Button for opening the main menu

After power up the instrument first performs a self-test which takes about 30 seconds. After the self-test and the warm-up phase the instrument is automatically ready for operation.

- The instrument is now ready for measurement and the operator can perform a test measurement.

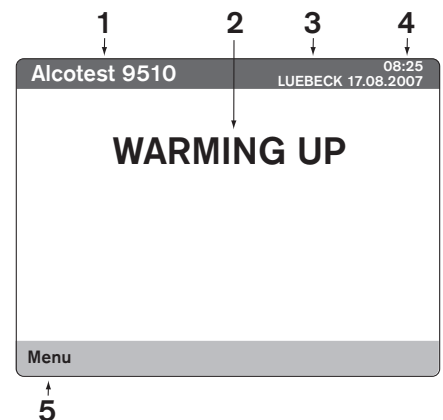

01023875_01_en.nppa

Screen Standby Mode

If not interaction with the instrument occurs for 30 minutes, the screen is dimmed.

- Touch the screen in order to re-activate it.
- The screen display is immediately shown again.

or

- Press the green start button under the screen.
- Either a measurement or the warm-up phase is started, and the screen is activated.

Menu

Use the touch screen option of the screen for selecting menu items. Use the stylus to operate the touch screen.

⚠ CAUTION
Exclusively use the stylus for operating the touch screen. Any other tools (e.g. a ball pen) can damage the touch screen irreversibly.

If no external keypad is connected for data entry, the screen automatically indicates a virtual keypad which can be operated using the stylus.

The » **About** « and » **Settings** « menus can be selected directly from the start bar under the menu button.

The » **Maintenance** « menu is only accessible for persons with administrator rights. For this reason, the text is greyed.

» About « Menu

This menu provides information about the installed software version. The picture shows an example.

(The version No. should be communicated when remarks and comments related to the measuring procedures of the Alcotest 9510 are given).

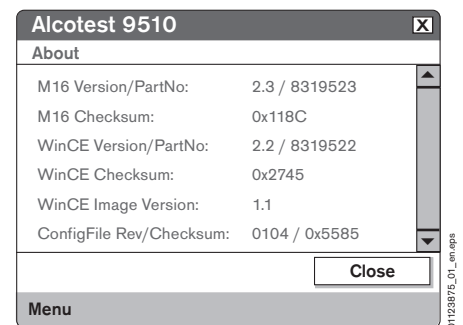

» Maintenance « Menu

This menu cannot be selected unless you have administrator rights.

For authorised persons, only.

(The text is greyed in order to indicate that access is not possible.)

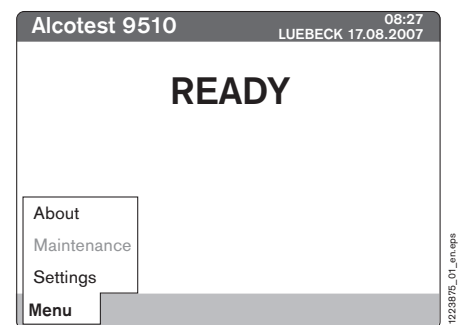

» Settings « Menu

In this menu, you can set or select the location, time, language, etc.

- A menu item can be selected by double-clicking it with the stylus or by navigating to it using the arrow keys on the keypad.
- The Settings submenu can be closed by clicking the cross in the top right corner of the screen.

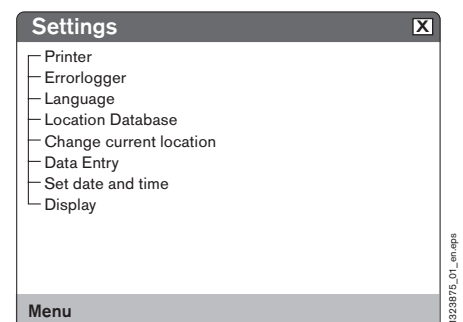

» Printer « Submenu

In the "Printer" submenu, you can select the internal or an external printer for protocol printing.

- If the instrument has been configured correspondingly, the number of printed copies is either fixed to 1 copy or it is possible to select a number between 1 and 5 copies.
- If no printer is selected, no protocol is printed.
- In the basic setting, the internal printer is set to "On" and the number of copies is set to 1.
- Complete your settings and changes with the [Confirm] button. You will automatically return to the menu.
- If you have opened this submenu only for verifying the settings, click the cross in the top right corner of the screen or use the [Close] button to return to the menu.

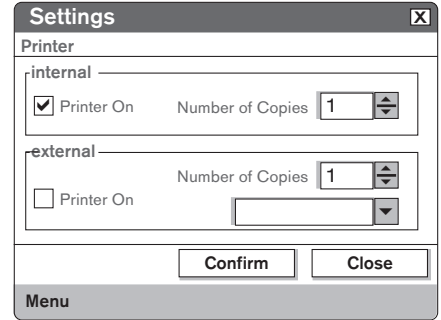

» Errorlogger « Submenu

In the "Errorlogger" submenu, errors that occur during operation are saved.

- The following information is logged: the error category, the date and time, and the error code. Errors in this sense are operating states which impede any further operation of the instrument.
- Close the "Errorlogger" submenu by clicking the cross in the top right corner of the screen.

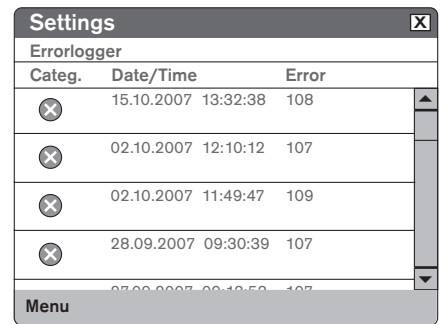

» Language « Submenu

- In the "Language" submenu you can select one of the indicated languages. The Alcotest 9510 Standard IR + EC in its basic configuration offers English and German as default languages. Optionally, a third language can be added.
- Mark the desired language in the selection window.
- Activate your selection with [Confirm].
- The selected language is loaded. You will then automatically return to the menu.

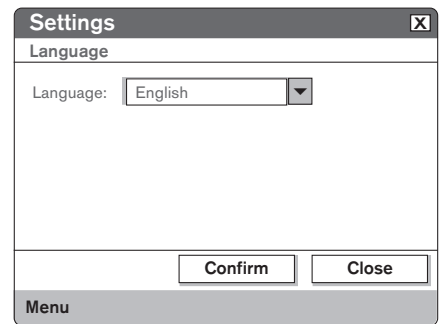

» Location Database « Submenu

The "Location Database" submenu provides the opportunity to enter additional locations which can then be selected when performing a measurement.

- The maximum admissible length of an entry is 17 characters. A maximum of 10 locations can be entered.
- Complete your settings and changes with the [Confirm] button. You will automatically return to the menu.
- If you have opened this submenu only for verifying the settings, click the cross in the top right corner of the screen or use the [Close] button to return to the menu.

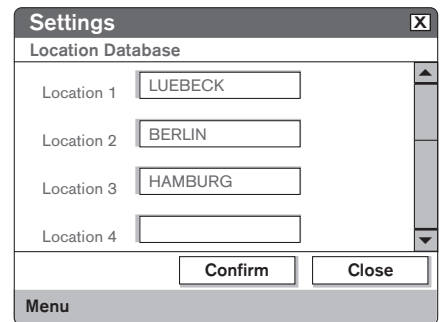

» Change current location « Submenu

In this submenu, you can select the location, which is to be indicated in the second line of the display.

- Select the wanted location by "clicking" it; it is then highlighted by a marking bar.
- After having selected the location, use the [Confirm] button to exit the submenu.
- The selected location is shown in the display and is printed with the protocol.
- If you have opened this submenu only for verifying the settings, click the cross in the top right corner of the screen or use the [Close] button to return to the menu.

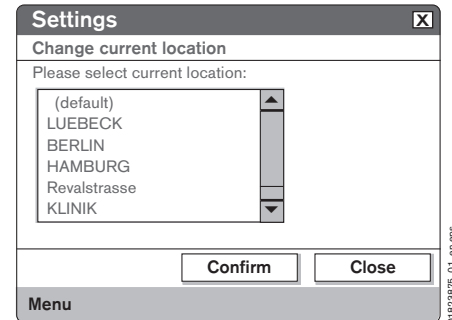

» Service Settings « Submenu

In the "Service Settings" submenu the request for data input during the measurement can be activated or deactivated.

- In the basic setting, the data input is activated.
- After having made this setting, use the [Confirm] button to exit the submenu.
- If you have opened this submenu only for verifying the settings, click the cross in the top right corner of the screen or use the [Close] button to return to the menu.

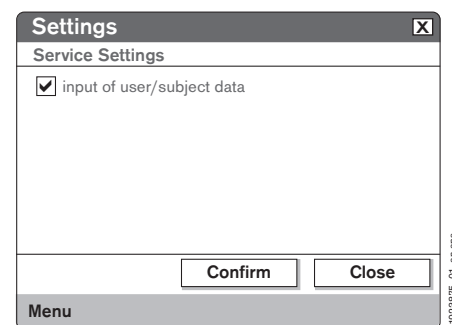

» Set date and time « submenu

In this submenu, you can set the date and time.

- Set the time and date one after the other and then select the time zone.
- After having entered the date and time, use the [Confirm] button to exit the submenu.
- If you have opened this submenu only for verifying the settings, click the cross in the top right corner of the screen or use the [Close] button to return to the menu.

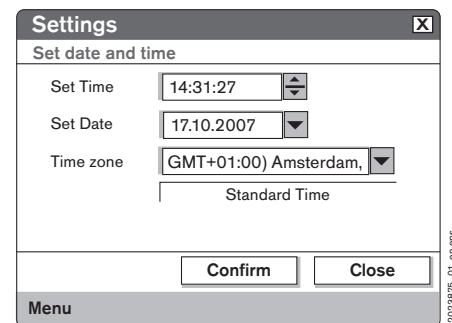

» Display « Submenu

In this submenu, the screen display can be rotated by 180°.

- Activate the display rotation (✓) and then use the [Confirm] button to exit the submenu. The screen display is rotated by 180°.

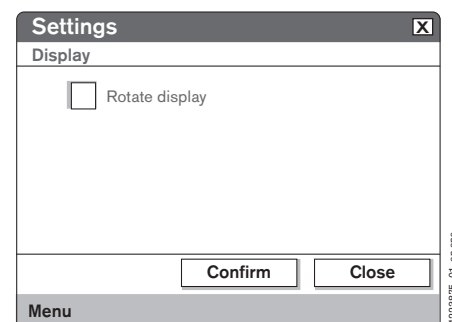

Making Measurement

Requirements

The measurements of the breath alcohol concentration using the Alcotest 9510 may be performed by trained users only!

- Ensure compliance with the permissible ambient conditions (see page 24).

Control Time before Measurement

Basically, the following has to be considered for breath alcohol measurement:

- It must be ensured that during a time period of at least 10 minutes before the measurement no substances are taken in through the mouth or nose.
- Alcohol residues that are still in the mouth may cause incorrect measuring values.
- This may also occur by aromatic drinks (e.g. fruit juices), alcoholic mouth sprays, medicines and drops, as well as by burping and vomiting. Rinsing out the mouth with water or non-alcoholic drinks does not substitute for this control time!

Starting Measurement

- Press the green start button under the screen in order to start a measurement.

If the instrument is in standby mode indicated by the » STANDBY « message on the screen:

- Press the start button before actually starting the measurement in order to establish the instrument's readiness for operation.
- Depending on the instrument setup, it may be necessary to enter the data of the person being tested before starting the measurement.
- Press the [>>>] or [Reset] button to finish the entry of the respective data.

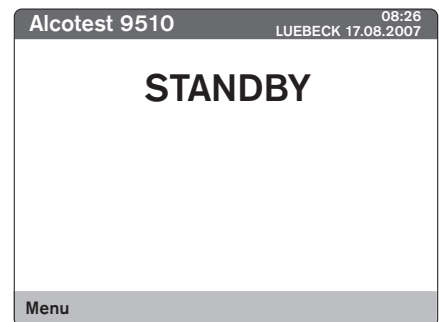

Entering Data of Person Being Tested

The figures show how to enter the data via the virtual keypad. When using an external keypad, the entries must be made correspondingly via this keypad .

- If no entries are made for 10 minutes, the message » DATA INPUT TIMEOUT « is indicated and the instrument returns to » READY « mode.

The first prompt is » SUBJECT LAST NAME «:

- Enter the name of the person being tested via the keypad.
- Up to 24 letters can be entered for the name. For names with more letters/characters the last character is accepted in the 24th. position. The entry has to be finished with the [>>>] button.

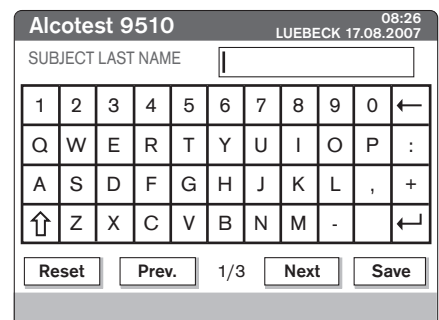

The display then changes over to » SUBJECT FIRST NAME «:

- As the second information the first name of the person being tested, again with up to 24 letters, has to be entered. The entry also has to be finished with the [>>>] button.

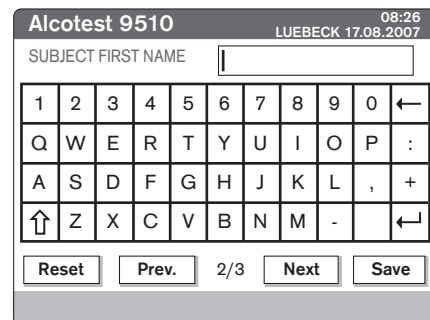

Thirdly the date of birth of the person being tested is requested.

- For this data input only the day (DD), month (MM) and year (YYYY) of birth have to be entered.
 - Note that two digits must be entered for the day and month and 4 digits for the year (e.g. >04< for the month of April).
 - The data entry is checked internally for consistency concerning the day and month. The 31.4.56 would for example not be accepted. When entering a non-reasonable date, this entry will be rejected upon pressing of the [Summary] button; then you are prompted to enter the date again.
- The entry has to be finished with the [Summary] button.

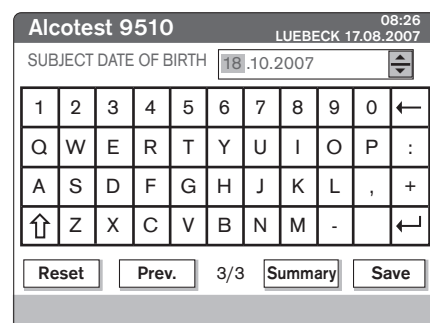

- After entry of all data for the person being tested, the instrument displays a summary of all entries.
- Up to this point all previous entries can be recalled into the display by pressing the [<<<] button.
 - You can either modify these entries by entering new data or confirm you entries by pressing the [Save] button.
- When using an external keypad, you can also terminate the data entry by pressing the keys [alt] + [s].
- When pressing the [Save] button to confirm the entry of the data for the person being tested, the measurement starts immediately – at this point you can no longer return to your previous entry by pressing [<<<].

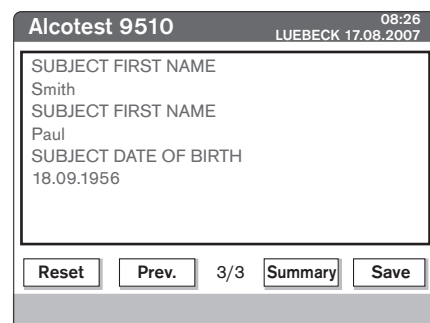

- The measuring cycle is continued with the display:

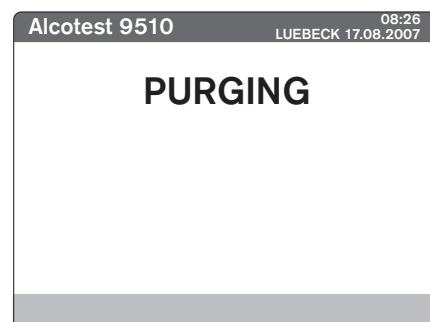

In the Alcotest 9510 the ambient air is analysed for alcoholic vapours. The display shows:

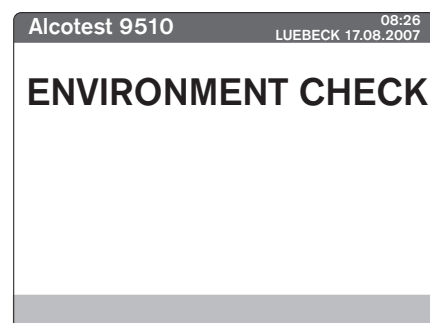

If influences from the ambient air can be excluded with this test, the zero value is determined, shown by:

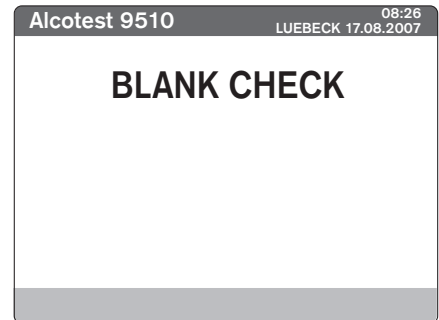

After this action the instrument requests a breath sample:

- Open the packaging of a new mouthpiece, take the breathing hose out of the storage recess and insert the mouthpiece into the handle at the end of the breathing hose; use the packaging to avoid skin contact.

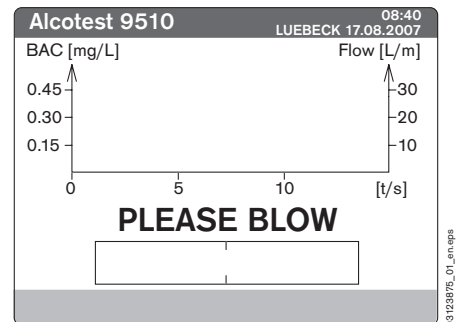

Delivering a Breath Sample

The operators of the instrument must ensure that the person being tested has not taken in any substances through the mouth or nose during the control time (at least 10 minutes) before the delivery of the breath sample.

When the display starts to show » PLEASE BLOW « the instrument is ready for measuring a breath sample for 3 minutes. Within this time period the person being tested has to deliver a breath sample.

- Ask the person being tested to inhale calmly and then blow continuously and evenly through the mouthpiece until the bargraph in the display is filled completely.
 - During the delivery of the breath sample the progress is indicated by the bargraph being filled.
 - The remaining length of the bargraph to be filled is a measure of the volume still required before reaching the minimum volume.
 - It is, however, possible to continue the delivery of the breath sample when the bargraph is already filled completely. This does not affect the measurement.

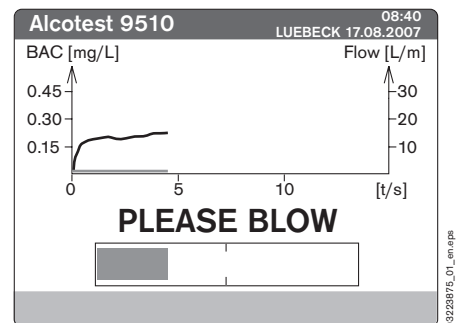

If the breath flow falls below the minimum flow at the end of breath sample delivery, the display indicates » STOP «.

- The delivery of the breath sample must be stopped immediately. A restart (reblow) must be avoided in any case – measuring error.

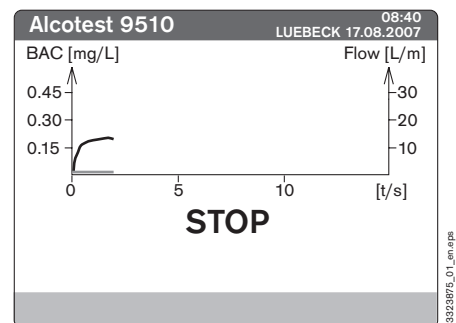

- If the requirements for the delivery of the breath sample are fulfilled concerning the duration, volume and continuity, the mouthpiece has to be removed from the handle at the end of the breathing hose after the corresponding request. The mouthpiece packaging has to be used for this and the mouthpiece has to be disposed.
- The breathing hose has to be placed in the storage recess or on the side of the instrument.

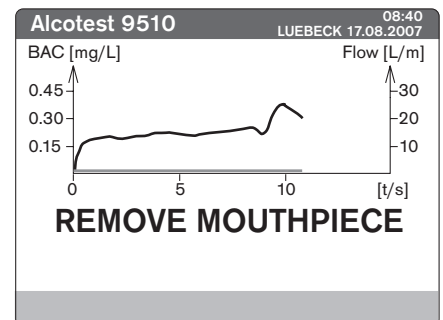

The measuring system is purged again with ambient air, and another internal alignment is performed, indicated by:

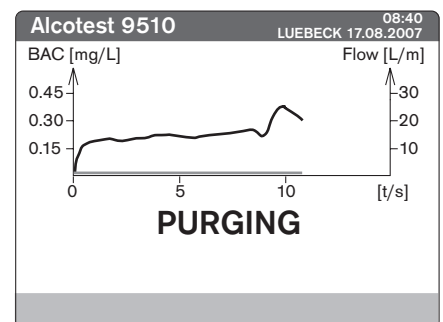

Subsequently, the final result is shown in the display, provided that all requirements of the procedure are fulfilled.

Example:

- Measurement results below 0.03 mg/L resp. 0.05 ‰ are output as 0.00 mg/L resp. ‰. For other measurement units corresponding display limits are valid.
- Printing of the protocol is started.



Finishing the Measuring Cycle

When printing is finished, the display shows:

- Readiness for operation is re-established for the next measuring cycle.

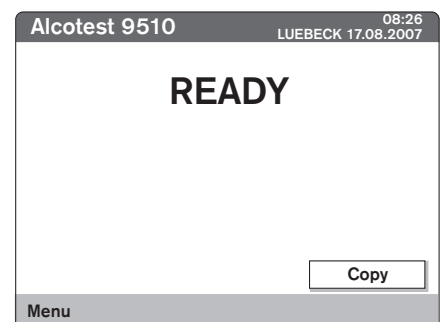

Printing an Additional Measurement Protocol

A copy of the last printed protocol can be printed by pressing the [Copy] button at a later time, provided that the next measurement has not yet been started. A subsequently printed copy also contains all data of the measurement.

Faults during the Measurement Cycle

Various instrument checks are performed during the measurement; each breath sample is checked for usability and correct delivery using certain criteria. If faults are detected in the measurement cycle, they are indicated in the display. Depending on the type of fault, the breath sample delivery must be repeated or the measurement cycle is cancelled.

If, for example, the volume of the delivered breath sample is insufficient, the following display is indicated:

- The breath sample must be delivered again. (A total of 3 unsuccessful attempts per measuring cycle is permissible.)

The repetition of the breath sample is noticed by:

The instrument automatically becomes ready for measurement again.

Identically the measuring cycle is continued if the following message is indicated, e.g. due to a too short delivery of the breath sample (less than 3 seconds).

It always has to be ensured that the air way into the breathing hose is not obstructed during rinsing. If the controlled flowrate during rinsing is too low, the following message is shown:

For breath samples with both too small exhalation volume and too short exhalation time, the error message concerning the breath volume is shown.

After a fourth unsuccessful attempt the measuring cycle is cancelled, the message » TEST ABORTED « is shown and the corresponding message stating the reason of the last unsuccessful attempt is printed on the protocol.

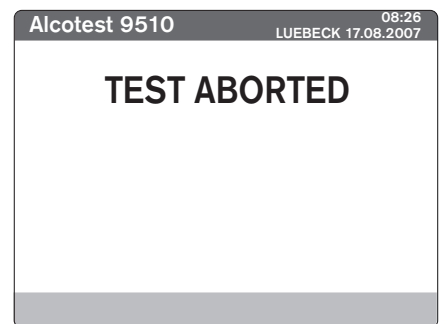
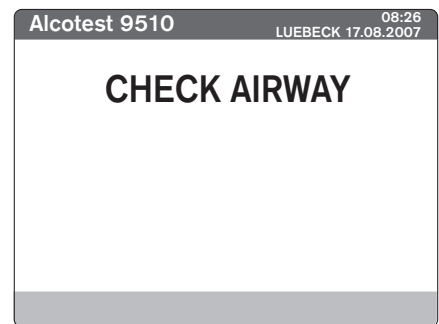
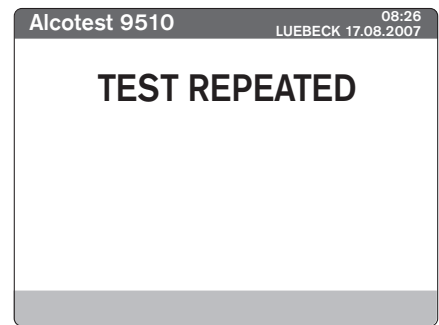
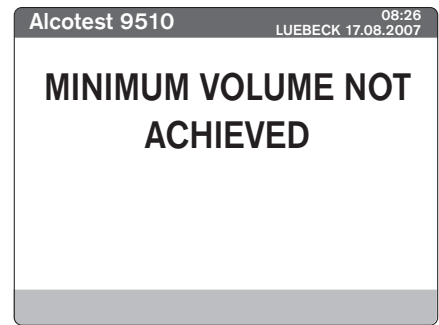

If the presence of mouth alcohol is detected in the concentration-time-profile, the following message is output:

The measuring cycle is immediately cancelled and a protocol with the corresponding information is printed.

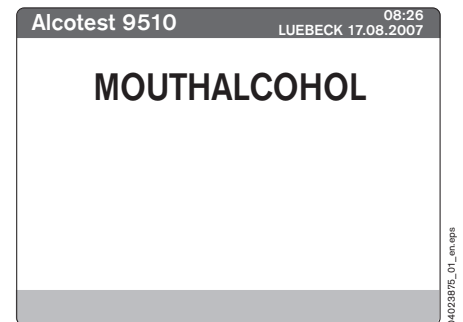

If within 3 minutes after the prompt no test sample delivery is started, the measuring cycle is also cancelled.

The display shows the corresponding message:

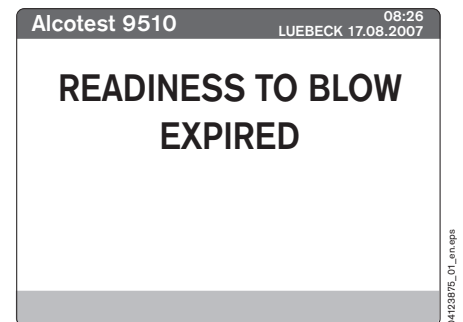

A protocol with the corresponding information is printed.

Measurement Protocols (Examples)

(Example: normal measurement)

(Example: cancelled measurement cycle)

0 1 2 3 4 5 6 7 8 9

DRAEGER ALCOTEST 9510

SERIAL NO.: ARXN-0002
TEST NO.: 00063
CALIBR.: 00001

Date: 15.08.07
Start Time: 18:08 S
Stop Time: 18:11 S

LOCATION:
LUEBECK

NAME SUBJECT:
Smith

FIRST NAME:
Peter

DATE OF BIRTH:
18.09.1956

SUBJECT MEASUREMENT
FAILED BLOWINGS : 0
BLOWING VOLUME : 3.0 L
BLOWING TIME : 13.8 s

SUBJECT : 0.00

* RESULT *
* *
* 0.00 mg/L *
* *

NAME OPERATOR:

SIGNATURE OPERATOR:

0 1 2 3 4 5 6 7 8 9

0 1 2 3 4 5 6 7 8 9

DRAEGER ALCOTEST 9510

SERIAL NO.: ARXN-0002
TEST NO.: 00064
CALIBR.: 00001

Date: 15.08.07
Start Time: 19:10 S
Stop Time: -:- S

LOCATION:
LUEBECK

NAME SUBJECT:
Mustermann

FIRST NAME:
Manfred

DATE OF BIRTH:
18.09.1956

SUBJECT MEASUREMENT
FAILED BLOWINGS : 4
BLOWING VOLUME : 0.5 L
BLOWING TIME : 5.8 s

SUBJECT : —

* RESULT *
* *
* MINIMUM VOLUME *
* NOT ACHIEVED *

NAME OPERATOR:

SIGNATURE OPERATOR:

0 1 2 3 4 5 6 7 8 9

Explanation of the Protocol

The information given in the upper part of the protocol allows for an unambiguous identification of the measuring instrument which performed the measurement and printed the protocol.

- Serial number: unambiguous information (4 characters, 4-digit number) assigned to exactly one instrument.
- Test number: number of measurements with protocol printout after the last service at which the counter has been reset.
- Calibration number: control number which is changed when adjusting the instrument.

The other information in the protocol is self explanatory.

Summer Time/Winter Time Change-Over

The time set in the Alcotest 9510 Standard is indicated with the current time by an additional character. The clock is automatically put forward or backward by one hour and the corresponding additional character is indicated.

Summer time/winter time change-over

The Alcotest 9510 Standard IR + EC automatically changes over from winter to summer time and vice versa. No user interaction is required.

Maintenance

Inspection

Inspection of the Alcotest 9510 Standard have to be performed by experts, e.g. by Dräger Safety or by persons authorised by Dräger Safety.

Maintenance Intervals

recommended: 6 months

maximum: 12 months

Inserting Paper Roll

When a measurement is started, the Alcotest 9510 Standard checks whether sufficient paper is in the printer. If not enough paper is available, the message » NO PAPER « is indicated.

- When the red strip appears on the print-out, a new paper roll has to be inserted.
- In order to be able to open the printer flap, press the black unlocking button and open the flap.
- Insert a new paper roll.
- In order to allow for a storage of the printed protocols for a long time period, it is strongly recommended to use the thermal paper offered by Dräger Safety (see "Order List", "Consumables and Accessories", page 26).

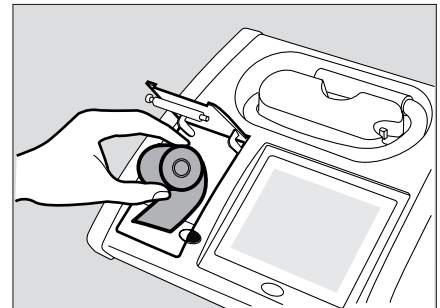

Replacing Fuses

- Disconnect the instrument from the power supply.
- Press the lock of the fuse holder together and pull out the fuse holder.
- Replace the old fuses with new ones.
- Exclusively use the specified fuses.
See "Order List", "Consumables and Accessories", page 26.
- Re-insert the fuse holder.

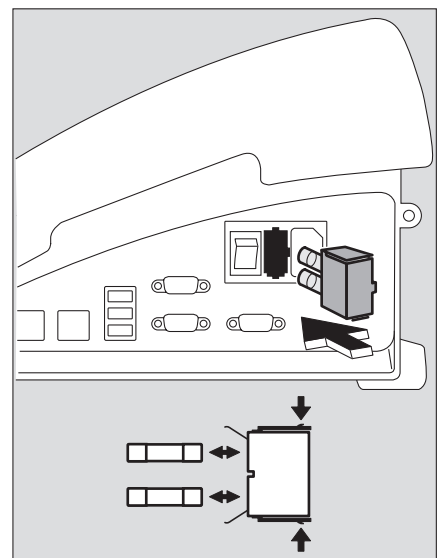

Cleaning the Instrument

- Disconnect the instrument from the power supply.
- Wipe the surfaces of the instrument and the hose clean using a damp cloth.
- Dry thoroughly with a dry cloth.
- Do not use any cleaning agents containing alcohol.
- Do not allow any liquid to ingress into the hose.

Disposal of Electric and Electronic Instruments



From August 2005, regulations apply to the whole of the EU for the disposal of electrical and electronic instruments; these regulations are set in the EU



Directive 2002/96/EC and in national laws relating to this instrument.

Special collection and recycling possibilities have been established for private households. However, since the instrument has not been registered for use in private households, it cannot be disposed of as special household waste. For disposal, it can be sent back to your national Dräger Safety Sales organisation; if you have any questions requiring disposal, then please contact this location.

Fault – Cause – Remedy

Fault » Display « (Printer Text)	Cause	Remedy
No function after power-on	Fuses defective	Check the fuses, replace if required, see page 20
	Poser supply insufficient.	Check power supply.
» BLANK CHECK INCORRECT « (BLANK CHECK INCORRECT)	Zero adjustment incorrect.	Ensure that ambient air is clean and free of alcohol. Air test room.
» MOUTHALCOHOL « (MOUTHALCOHOL)	Residual alcohol in the mouth of the person being tested. Person has drunk alcohol directly before test or has burped.	Remedy cause. Repeat measurement after waiting time. Observe control time.
» TEST DISCONTINUED « (TEST DISCONTINUED)	The supplied volume is smaller than the minimum volume required.	The instrument automatically requests to repeat the breath sample.
» BLOWING TIME TOO SHORT « (BLOWING TIME TOO SHORT)	The time for which the breath sample is delivered is shorter than the minimum requested.	The instrument automatically requests to repeat the breath sample.
» BLOWING NOT ALLOWED « (BLOWING NOT ALLOWED)	Breath sample delivery at a not permitted time, instrument not ready for measurement (reblow).	Instruct person being tested for correct delivery of breath sample. Start new measurement.
» READINESS TO BLOW EXPIRED « (READIN. TO BLOW EXP.)	Readiness for measurement of 3 minutes has expired. Breath sample delivery has not started within this time window.	Start new measurement.
» ALCOHOL IN THE ENVIRONMENT « (ALCOHOL-ENVIRONMENT)	Contamination of ambient air detected.	Ensure that ambient air is clean and free of alcohol. Air test room.
» PURGING ERROR « (PURGING ERROR)	Necessary volume for purging the measuring system not reached.	Check breathing hose inlet. If no abnormalities are found: restart measurement. If fault occurs again: inform Dräger Safety.
» DATA INPUT TIMEOUT « (DATA INPUT TIMEOUT)	No data input within 10 minutes despite prompt.	Start new measurement. Enter data when prompted to do so.
» INTERFERENCE « (INTERFERENCE)	The two independent measuring systems have detected an inadmissible influence on the measured values by foreign substances in the breath.	Identify cause of the influence, remedy if possible. If required initiate other evidential measures.

Fault » Display « (Printer Text)	Cause	Remedy
<p>The following errors are indicated on the screen in English language with an error code and a text message: » ERROR [XXX]MAIN-SYSTEM « ..IR-SYSTEM « ..EC-SYSTEM « ..FLOW-SYSTEM « ..PRESSURE-SYS « ..HEATER SYSTEM «</p> <p>Example: ERROR [118] HEATER SYSTEM</p> <p>The error code and the text message are printed on the printer. Example: Error [118] HEATER SYSTEM</p>	<p>Instrument defective (XXX = code specifying the error)</p> <p>Instrument blocks automatically all measurement cycles when detecting this error.</p> <p>The set temperature for the sensor or hose is not reached.</p>	<p>Switch off instrument. Check whether the error re-occurs after switching on again. If yes: inform Dräger Safety. Submit instrument for repair.</p> <p>Ensure compliance with the ambient conditions. Switch off instrument, if required put on instrument cover and switch on again. If the error should re-occur upon switch-on, inform Dräger Safety.</p>

Messages generated by the Windows CE operating system

(Usually full text messages are generated, in parts with options allowing to select further actions).

Fault / Display	Cause	Remedy
<p>Instrument not ready for operation Service function is not possible.</p>	<p>Selected action is only possible when instrument is » READY «.</p>	<p>Wait until readiness for operation is established.</p>

Technical Data

Ambient conditions

Operational characteristics

- Temperature range 0 to 40 °C
- Humidity 30 to 90 % relative humidity
- Ambient pressure 700 to 1300 hPa (20.7 to 38.4 inch Hg)

Storage

- Temperature range -20 to 70 °C (>40 °C only for some hours)
- Humidity 10 to 90 % relative humidity
- Ambient pressure 700 to 1300 hPa (20.7 to 38.4 inch Hg)

Measuring system

Measuring range

- Breath alcohol concentration 0 to 3 mg/l
0 to 300 µg/100ml / 0 to 3000 µg/l
(Ethanol mass per respiratory volume at 34 °C and 1013 hPa)
- Blood alcohol concentration 0 to 6 ‰
0 to 6 g/l
0 to 0.6 %
(Ethanol mass per blood volume at 20 °C and 1013 hPa.
When giving this data a conversion factor of 2100 between
breath and blood alcohol concentration is used.)

Resolution final result

0.01 mg/l
1 µg/100 ml
10 µg/l
0.01 ‰
0.01 g/l
0.00%

Duration of measurement (typical)

3 minutes

Blowing time

3 seconds

Respiratory volume

>1.5 l

Repeatability:

- 0 to 0.4 mg/l standard deviation < 0.007 mg/l
- above 0.4 to 2.0 mg/l smaller than 1.75 % relative
- above 2.0 mg/l smaller than 6 % relative

Calibration interval

depends on required accuracy
recommended: 6 months; maximum: 12 months

Typical Operating Data

Power supply

Mains operation 110 to 240 V, 50 to 60 Hz

12 V operation 10.5 to 15.5 V DC

Power consumption

During warm-up phase approx. 70 W

in standby mode <15 W

Main fuse

TH/250 V; 0.63 A, 2 pieces

Thermal printer

Thermal printer with special paper, 58 mm wide

Time indication

Day/Month/Year

Hours: Minutes

Summer time/winter time

Warm-up phase

less than 15 minutes at room temperature

Dimensions

approx. 325 mm x 250 mm x 55/185 mm (W x H x D)

Weight (without keypad)

6.9 kg

CE markings

Electromagnetic compatibility (Directive 89/336/EEC)

Low-voltage directive (Directive 72/23/EEC)

Order List

Designation	Part No.
Dräger Alcotest 9510	83 18 400
Standard IR + EC (variation)	83 19 470
Consumables and Accessories	
Keypad - Mini OWERTY (USB)	83 19 441
Carrying bag	83 19 155
12 V cable (with ON/OFF switch)	83 12 641
Printer paper (5 rolls, storable for 7 years)	83 19 002
Printer paper (5 rolls, storable for 25 years)	83 18 461
Mouthpiece with non-return valve (25 pieces)	68 05 703
Fuse, TH 250, 0.63 A	18 92 979

Index

» About « menu	9	fault – cause – remedy	22
» Change current location « submenu	11	fault (printer text)	22
» Errorlogger « submenu	10	fault » display «	22
» Language « submenu	10	faults during the measurement cycle	16
» Location Database « submenu	10	finishing the measuring cycle	15
» Maintenance « menu	9	front view	5
» Printer « submenu	10	function description	4
» Service Settings « Submenu	11		
» Set date and time « submenu	11	gas outlet	5, 6
» Settings « menu	9		
		humidity	24
12 V operation	25		
		inserting paper roll	20
accessories	3, 26	Inspection	20
alcohol concentration	4	intended use	4
ambient conditions	24	interaction with the instrument	8
ambient pressure	24		
		keypad	8
back view	5		
blood alcohol concentration	24	main fuse	5, 25
blowing time	24	mains inlet	5
breath alcohol concentration	24	mains operation	25
Breathing hose	5	mains switch	5
		Maintenance	20
calibration interval	24	maintenance	3
cancelled measurement cycle	18	Maintenance Intervals	20
car battery	6	maintenance jobs	3
CE marking	25	making measurement	12
cleaning the instrument	20	measurement protocol	18
Commissioning	6	measuring range	24
connection of electrical instruments	3	measuring system	24
connector 12 V DC	5	menu	9
consumables	26	mobile use	6
control time before measurement	12	modem connector	5
		monitor connector	5
delivering a breath sample	14	network connector	5
dimensions	25	normal measurement	18
disposal	21		
duration of one measurement	24		
		operating data	25
entering data of person being tested	12	order list	26
error code	10		
explanations of the protocol	19	potentially explosive atmospheres	3
		Power consumption	25
		preparing the measurement	6
		printing an additional measurement protocol	15

repeatability	24
replacing fuses	20
resolution final result	24
respiratory volume	24
RS 232 interface	5
safety	3
safety symbols	3
screen	5, 8
screen standby mode	8
service contract	3
side view	5
standby mode	7
start button	5
starting measurement	12
stationary use	6
storage	4
stylus	5
summer time/winter time change-over	19
Supply voltage	25
Technical data	24
temperature range	24
thermal printer	5, 25
touch screen	5, 8
transport	4
type plate	5
USB port	5
warm-up phase	6, 25
weight	25
Windows CE operating system	23

Dräger Safety AG & Co. KGaA

Revalstraße 1

D-23560 Lübeck

Germany

Tel. (04 51) 8 82 - 0

Fax (04 51) 8 82 - 20 80

www.draeger.com

90 23 875 - GA 4756.101 en

© Dräger Safety AG & Co. KGaA

1st edition - November 2007

Subject to alteration